

## INSTALLATION

The transmitter is intended for DIN rail mounting. Its drawing is presented in figure 4.

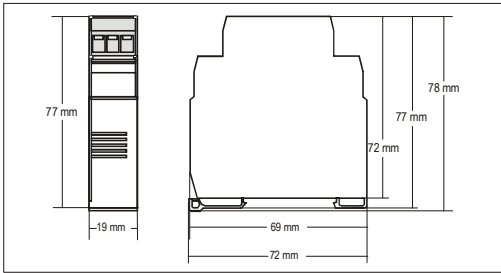

Figure 4 – Transmitter dimensions

## ELECTRICAL CONNECTIONS

### Connector specification:

- Insulating material: Polyamide, self-extinguishing to UL 94, V-0
- Connection wire cross section: 0,14 – 4,0 mm<sup>2</sup> / AWG 28-14
- Screw tightening torque: 0,8 Nm / 7.0 lb-in
- Terminal block: CuZn

### It is important to follow the recommendations below:

- Signal wires should be installed in grounded conduits and away from power or contactor wires.
- The instrument should have its own power supply wires, which should not be shared with electrical motors, coils, contactors, etc.
- Installing RC filters is strongly recommended at contactor coils or any other inductors.
- System failure should always be taken into account when designing a control panel to avoid irreversible damage to equipment or people.

For 0-10Vdc input, the transmitter requires an internal hardware configuration change. Please open the instrument case and change the jumper shown in Figure 7.

- Position 1-2 : 0-10Vdc input
- Position 2-3 : all other input types (factory setting).

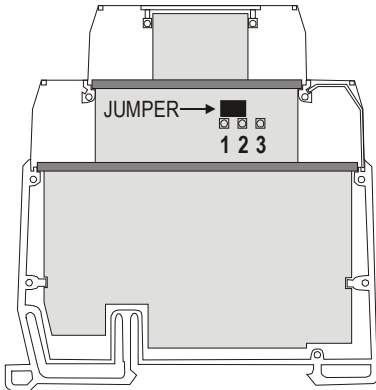

Figure 7 – Jumper position for 0-10Vdc input

Figure 5 below shows the transmitter connections to the sensor and power supply. Terminals 1, 2 e 3 are used for sensor input. For 2-wire Pt100, terminals 2 and 3 shall be connected together.

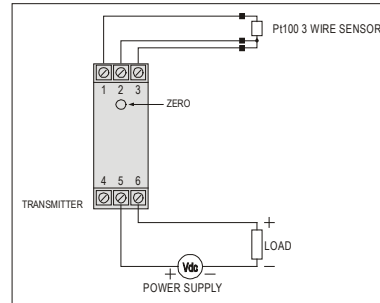

Figure 5 – Transmitter wiring (Pt100)

Figure 6 below shows the thermocouple wiring.

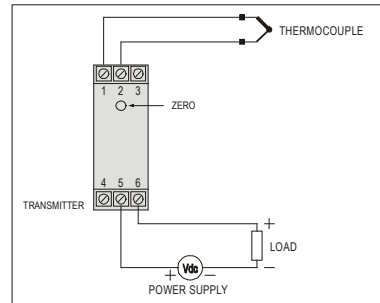

Figure 6 – Transmitter wiring (Thermocouple)

The **LOAD** represents the input shunt of an instrument measuring the 4-20 current loop.

## OPERATION

All input types and the 4-20mA output current are factory calibrated. However, a manual offset trim is implemented to provide fine adjustments to the signal in the field. This is accomplished by means of short circuiting terminals 4 (Zero) and 1 (-). The transmitter waits 2 seconds before it starts changing the offset. The offset adjustment is capable of varying the output current by an amount equal to  $\pm 0.80\text{mA}$  relative to the original calibration. After reaching the maximum value ( $0.80\text{mA}$  above the original current), the output is driven instantly to  $-0.80\text{mA}$  below the original current, and continues increasing. When the desired output current (offset) is reached, opening the jumper will cause the TxIsoRail to acknowledge the new offset value. Fine trimming is possible with momentary (2s minimum) jumper contact.

The offset correction can also be accomplished by the TxConfig software. See in Figure 3 the **Zero Correction** field for this purpose. The serial adaptor can be connected to the transmitter while it is operating in the process.

**Note:** when using a Pt100 simulator, make sure the Transmitter Pt100 excitation current ( $0.18\text{mA}$ ) is compatible with the simulator specification.

The input types are listed in Table 1, along with the maximum and minimum ranges accepted by each one. The TxConfig software will allow only configurations that are consistent with the data in this table.

Please note that the specified accuracy is referenced to the maximum span of each input type. For instance, for the Pt100 input, the 0.15% accuracy results in  $1.2^{\circ}\text{C}$  total accuracy  $[(600 - (-200)) \times 0.15]$ .

# MICROPROCESSOR BASED TEMPERATURE TRANSMITTER

## TxIsoRail 4-20mA

### INSTALLATION AND OPERATING MANUAL

**NOVUS**  
PRODUTOS ELETRONICOS LTDA

www.novusautomation.com

## PRESENTATION

The TxIsoRail is a 2-wire DIN rail mount signal transmitter. Microprocessor based, it was designed for flexibility, accepting mV, V, mA, Pt100 and a variety of thermocouples as the input sensor.

The Transmitter delivers a scalable linear 4-20mA output current proportional to the input signal. A user-friendly configuration software is provided for parameter setup, including sensor type, temperature range, filter, etc.

## SPECIFICATIONS

**Sensor input:** User defined. The supported sensors are listed in table 01, along with their maximum ranges.

**Thermocouples:** Types J, K, R, S, T, N, E and B to IEC 60584 (ITS-90). Impedance >> 1MΩ

**Pt100:** Excitation: 180μA., 2 or 3-wire connection (for 2-wire sensors, tie terminals 2 and 3 together). α= 0.00385, according to IEC 60751(ITS-90).

**Voltage:** 0 to 50mVdc, 0 to 10Vdc. Impedance >> 1MΩ.  
0 to 20mA, 4 to 20mA. Impedance >> 1MΩ.

Sensor Type	Range	Minimum measurement span
Thermocouple K	-150 to 1370°C	100°C
Thermocouple J	-100 to 760°C	100°C
Thermocouple R	-50 to 1760°C	400°C
Thermocouple S	-50 to 1760°C	400°C
Thermocouple T	-160 to 400°C	100°C
Thermocouple N	-270 to 1300°C	100°C
Thermocouple E	-90 to 720°C	100°C
Thermocouple B	500 to 1820°C	100°C
Pt100	-200 to 600°C	40°C
Voltage	0 to 50mV	5 mV
	0 to 10V	1 V
Current	0 to 20mA	2 mA
	4 to 20mA	2 mA

Table 1 – Transmitter input sensors

**Output:** 2-wire 4-20mA, linear with respect to the measured signal.

**Total accuracy:** better than 0,3% of the maximum range for thermocouples and 0,2% for Pt100 and voltage;

**Resolution:** 0,001mA (14 bits).

**Response Time:** < 500 ms;

**Power supply:** 12 to 35Vdc, across the transmitter;

**Maximum load (RL):**  $RL (max.) = (V_{cc} - 12) / 0,02 [\Omega]$   
where:  $V_{cc}$ = Power supply voltage

**Operating Temperature:** -40 to 85°C

**Humidity:** 0 a 90% RH

**Electromagnetic compatibility:** EN 50081-2, EN 50082-2

**Isolation between the sensor and the 4-20mA loop (1000V / 1min).**

**Internal protection against polarity inversion.**

**Cold junction compensation for thermocouples.**

**Housing:** ABS plastic. Dimensions: Refer to figure 4.

## CONFIGURATION

Please check the configuration parameters programmed in the transmitter, using the **TxConfig** software. A communication path needs to be established between the transmitter and the serial port of a PC. The 1.5m long **TxConfig Interface** is provided for this purpose. Connect its DB9 end to the PC COMM port and the other end to the transmitter as shown in Figure 1.

Once configured, the transmitter is ready to be installed in the process.

**Note:** The TxConfig Interface and Software can be purchased separately from **Novus** or one of its distributors. The latest release of this software can be downloaded from our website. Do not save the TxConfig software into a file which contains accent marks. To install, run the **Tx\_setup.exe** and follow the instructions. To install de configurator, run the **Tx\_setup.exe** file.

Serial port configuration errors may occur when other devices are sharing the same port (ex.: Palm Hot Synch). Close all serial port applications prior to using the TxConfig software.

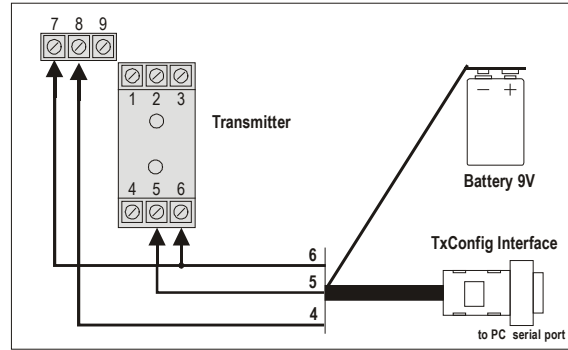

Figure 1 – Adaptor connections to the Transmitter

The transmitter requires to be powered during the configuration. Depending on the PC used, the power can be supplied by the serial port. To assure proper communication, it is recommended to apply external power to the transmitter. The TxConfig interface provides a 9V battery socket for powering the transmitter during the configuration.

Do not use the battery if the transmitter is being powered by another supply or connected to the process, as in Figure 2.

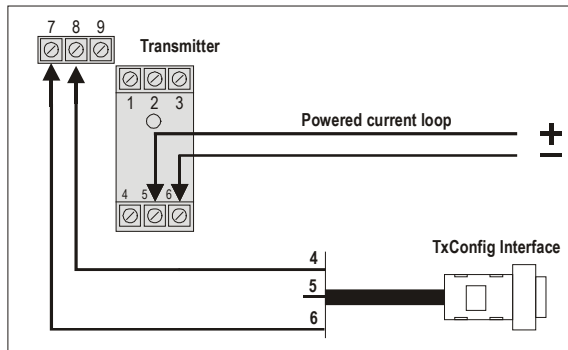

Figure 2 – Transmitter-TxConfig Adaptor wiring (loop powered). Terminal 5 is left opened.

The **TxConfig** screen in shown in Figure 3. All user parameters can be seen and/or modified by either typing a value or selecting among the available options. The help menu provides further information about the software and the transmitter.

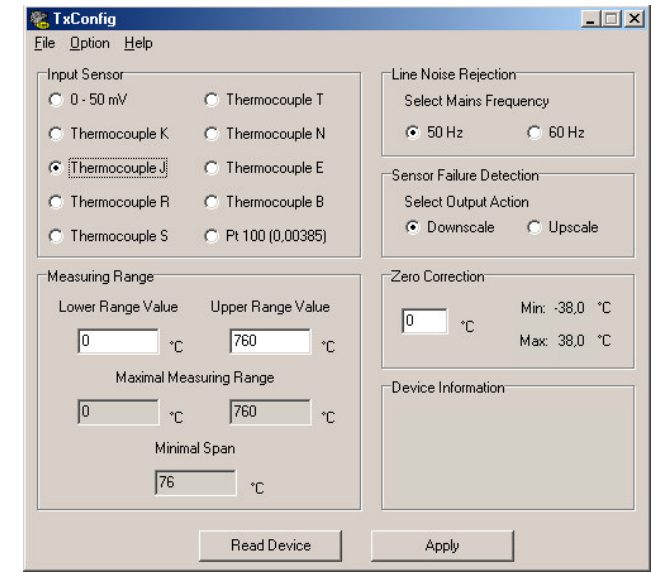

Figure 3 –TxConfig main screen

The fields in the screen mean:

- Input Sensor:** Choose the desired temperature sensor among the available options.
- Measuring range:** Defines the beginning and the end of the range.
  - Lower Range Value:** sets the value of the input signal (temperature or mV) associated to the 4mA output.
  - Upper Range Value:** sets the value of the input signal that will correspond to the 20mA output

The values configured in these fields can not be beyond the sensor measuring range. The minimum span value has to be observed as well (see Table 1).
- Line Noise Rejection:** The Transmitter incorporates a digital filter to cancel the induced noise from the 50 or 60 Hz systems. For better performance, select the line frequency used in your country.
- Sensor Failure Detection:** establishes the transmitter output behavior (upscale or down-scale) in the presence of a sensor fail.
- Zero Correction:** Allows for small sensor corrections.
- Read Configuration:** Brings to the screen the current Transmitter parameters configuration.
- Apply:** Sends a new configuration to the transmitter.
- Device Information:**

The *Device Information* box contains relevant data concerning a particular transmitter. Please pass along this information when contacting the technical assistance department.

**Note:** The factory default configuration is (unless otherwise specified or ordered):

  - Pt100 input, 0 to 100°C
  - 60Hz filtering and upscale (20mA) output for sensor fail.